

ARMADI E COMPONENTI PER RETI TRASMISSIONE DATI
19" COMPONENTS FOR DATA NETWORKS



CATALOGO



CATALOGUE



magnoni

MF

PKM

Gli armadi della serie PKM sono composti da un corpo principale e da una porta in vetro temprato.

Appartengono al sistema PKM due famiglie di prodotti, differenziate dalla profondità dell'armadio: PKM-400 e PKM-500.

Solo dopo aver aperto la portina frontale con la chiave, è possibile rimuovere le pareti laterali e accedere quindi alla parte posteriore del cablaggio.

PRINCIPALI VANTAGGI DEL SISTEMA

- Linea moderna e piacevole.
- Feritoie di aerazione predisposte sia nella parte superiore sia in quella inferiore.
- Predisposizione per il montaggio di una ventola di aerazione.
- Apertura ad oltre 180° della porta frontale.
- Possibilità di togliere la porta e di cambiarne il senso di apertura in pochi secondi anche dopo installazione.
- Pannelli laterali asportabili.

CARATTERISTICHE TECNICHE

- Corpo dell'armadio verniciato con polveri epossidiche in colore RAL7035 liscio.
- Profili-porta verniciati con polveri epossidiche in colore RAL7031 liscio.
- Porta in vetro temprato di sicurezza.
- Chiusura della porta frontale tramite serratura e chiave.
- Telaio 19" interno in lamiera zincata, regolabile in profondità per un posizionamento mirato in accordo alla profondità delle apparecchiature da installare.
- Passo di foratura del telaio 19" secondo la norma IEC 297-1.
- Predisposizione per messa a terra. Kit di cavi compreso nella fornitura.
- Protezione IP 20 a norma EN 60529.



PKM

PKM series cabinets are made up of a main unit and tempered glass door.

Two products families belong to the PKM system, with different cabinet depths: PKM-400 and PKM-500.

The removable side walls give access to the rear cabling while at the front door has been opened.

MAIN STRENGTHS OF THE SYSTEM

- Pleasant modern line thanks to the design of the top panel and the base.
- Ventilation flutes on both upper and lower areas.
- Possibility to install a fan.
- Over 180° door opening.
- Door hanging may be switched in a matter of seconds even after installation.
- Removable side panels.

TECHNICAL FEATURES

- Main structure painted with RAL7035 smooth epoxy powder paint.
- Door frame painted in RAL7031 smooth epoxy powder paint.
- Front tempered glass door with lock and key.
- 19" internal frame may be regulated in depth so as to position it in the most suitable way according to the depth of the equipment installed.
- IEC 297-1 borings on the 19" frame.
- Ready for round wiring. Cable kit included.
- IP 20 protection degree according to EN 60529 norm.



DIMENSIONI E CODICI PKM-400
PKM-400 DIMENSIONS AND CODES

Codice - Code	U-HE	L-W	P-D	H	Portata-Payload (Kg)
MAGN0749	6	600	413	360	30
MAGN0750	9	600	413	493	30
MAGN0751	12	600	413	626	30
MAGN0752	15	600	413	760	30
MAGN0972	21	600	413	1027	30

DIMENSIONI E CODICI PKM-500
PKM-500 DIMENSIONS AND CODES

Codice - Code	U-HE	L-W	P-D	H	Portata-Payload (Kg)
MAGN0753	6	600	513	360	30
MAGN0754	9	600	513	493	30
MAGN0755	12	600	513	626	30
MAGN0756	15	600	513	760	30
MAGN0973	21	600	513	1027	30

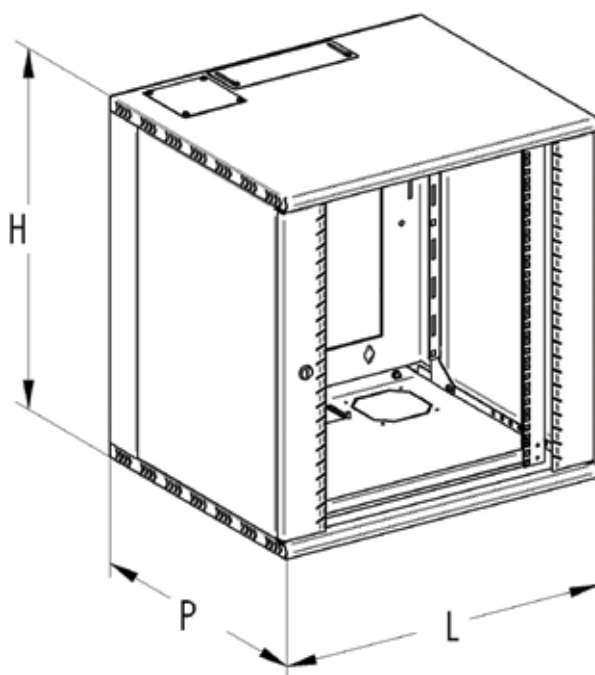

PORTE DI RICAMBIO IN VETRO PER PKM
PKM SPARE GLASS DOORS

Codice - Code

Cod. MAGN0820	6 U / HE
Cod. MAGN0821	9 U / HE
Cod. MAGN0822	12 U / HE
Cod. MAGN0823	15 U / HE
Cod. MAGN0984	21 U / HE



CASSETTO 19" PER VENTILAZIONE VERTICALE (1U) 19" VENTILATION DRAWER (1HE)

Cod. **95298535**
Con 3 ventole.
With 3 fans.
Grigio / Grey RAL7035



Cod. **95298545**
Con 6 ventole.
With 6 fans.
Grigio / Grey RAL7035

Cod. **95298536**
Con 3 ventole e termostato.
With 3 fans with thermostat.
Grigio / Grey RAL7035

UNITÀ DI VENTILAZIONE VENTILATION UNIT

Cod. **MAGN0832**
Tensione: 220/230 V
Rumorosità: 37 dB
Assorbimento: 16 W
Portata: 160 m³/h



TERMOSTATO PER ARMADI THERMOSTAT FOR CABINETS

Campo di impiego: 0/55 °C ± 2 °C
Differenziale Δt 3 ± 1K
Temperatura massima 65 °C

Cod. **MAGN0372**



CAPPUCCIO DI PROTEZIONE PER INTERRUOTTORE MAGNETOTERMICO PROTECTION COVER FOR CIRCUIT BREAKER

Per proteggere l'interruttore da urti accidentali.
To protect the switch from accidental switch-off.

Cod. **MAGN0541**

Grigio / Grey RAL7035

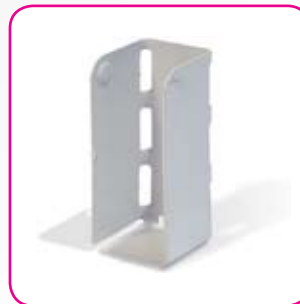

CANALINA DI ALIMENTAZIONE 19" (1,5U) 19" POWER SOCKET (1,5HE)

N.6 prese universali (1) con interruttore luminoso 16A-250V.
N.6 universal (1) sockets with 16A-250V luminous switch.

Cod. **MAGN0538** Grigio / Grey RAL7035
Cod. **MAGN0559** Nero / Black RAL9005

(A)

N.6 prese universali (1) con interruttore magnetotermico (2).
N.6 universal (1) sockets with circuit breaker (2).

Cod. **MAGN0537** Grigio / Grey RAL7035
Cod. **MAGN0558** Nero / Black RAL9005

(B)

8 prese universali (1) con spia luminosa.
8 universal sockets (1).

Cod. **MAGN0995** Grigio / Grey RAL7035
Cod. **MAGN0996** Nero / Black RAL9005

(C)



(1) Per "prese universali" si intende adatte agli standard: italiano, schuko tedesco, americano.

(1) Universal sockets= in compliance with Italian, German Schuko and American standards

(2) Interruttore magnetotermico 1P+N (un polo protetto + neutro) -16A - Curva C - Potere di interruzione 4,5 KA.

(2) 1P+N magneto-thermal switch (one protected pole plus neutral) -16A - Curve C - Circuit breaking capacity up to 4.5 KA.

RIPIANO FISSO 19" (2U), PROFONDITÀ 380 MM
19" SHELF (2HE), DEPTH 380 MM

Carico nominale: 30 kg distribuiti su tutto il ripiano.
 Nominal load: 30 Kg distributed over the whole shelf.

Cod. **95290280**
 Cod. **MAGN0092**

Grigio / Grey RAL7035
 Nero / Black RAL9005



SOLO PER PK 500-600
FOR PK 500-600 ONLY

RIPIANO FISSO 19" (2U), PROFONDITÀ 250 MM
19" SHELF (2HE), DEPTH 250 MM

Carico nominale: 20 kg distribuiti su tutto il ripiano.
 Nominal load: 20 Kg distributed over the whole shelf.

Cod. **95290295**
 Cod. **MAGN0093**

Grigio / Grey RAL7035
 Nero / Black RAL9005

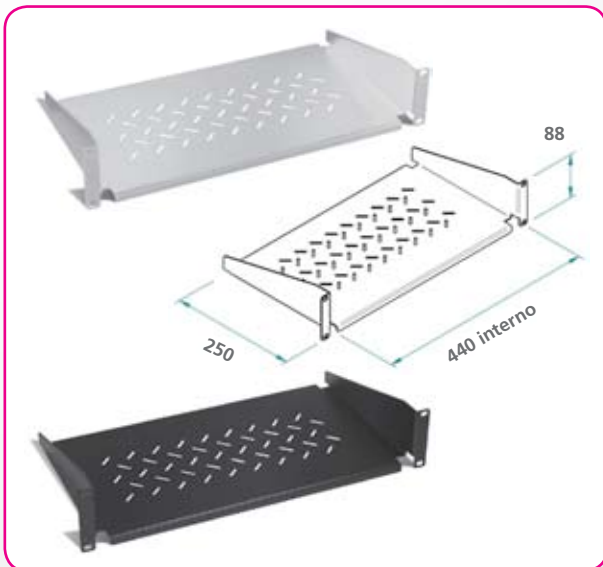

RIPIANO ESTRAIBILE 19" (2U), PROFONDITÀ 250MM
19" REMOVABLE SHELF (2HE), 250 MM DEPTH

Carico nominale: 30 kg distribuiti su tutto il ripiano.
 Nominal load: 30 kg distributed over the whole shelf.

Cod. **MAGN0141**
 Cod. **MAGN0342**

Grigio / Grey RAL7035
 Nero / Black RAL9005



PANNELLO PASSAPERMUTE
WIRE MANAGEMENT PANEL

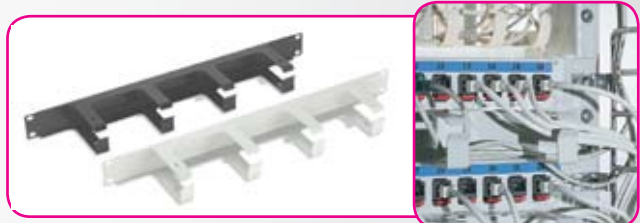

Cod. **95297096** P=90 A=1 U / HE Grigio / Grey RAL7035
 Cod. **95297097** P=90 A=1 U / HE Nero / Black RAL9005

PANNELLO PASSAPERMUTE FORATO
OPEN WIRE MANAGEMENT PANEL

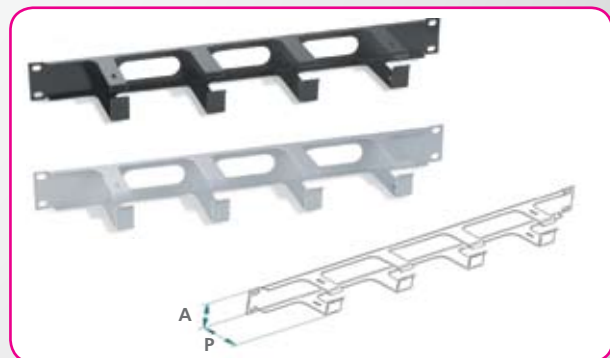

Cod. **MAGN0587** P=60 A=1 U / HE Grigio / Grey RAL7035
 Cod. **MAGN0671** P=60 A=1 U / HE Nero / Black RAL9005
 Cod. **MAGN0701** P=90 A=2 U / HE Grigio / Grey RAL7035
 Cod. **MAGN0702** P=90 A=2 U / HE Nero / Black RAL9005

ACCESSORI / ACCESSORIES

COPERCHIO PER PANNELLO PASSAPERMUTE (1U) COVER FOR WIRE MANAGEMENT PANEL (1HE)

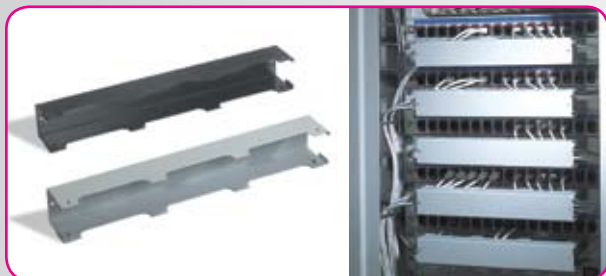

Cod. **MAGN0011** 1U / HE Grigio / Grey RAL7035

Cod. **MAGN0022** 1U / HE Nero / Black RAL9005

PANNELLO DI PERMUTAZIONE 19" (1U) PER 16 CONNETTORI RJ45 - VUOTO 19" PANEL FOR 16 RJ45 CONNECTORS (1HE) - EMPTY

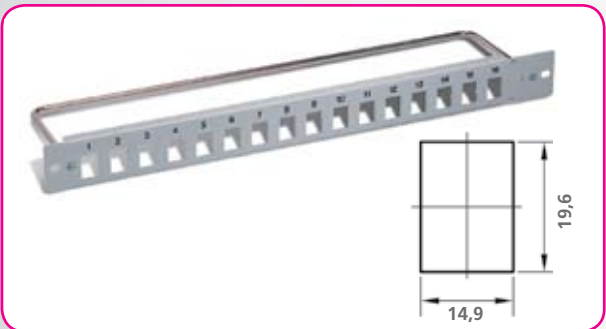

Cod. **95298635** Grigio / Grey RAL7035

Cod. **MAGN0807** Nero / Black RAL9005

PANNELLO DI PERMUTAZIONE 19" (1U) CON 24 CONNETTORI UTP 19" PANEL (1HE) WITH 24 UTP CONNECTORS

Cod. **MAGN1075 cat.5e** Nero / Black RAL9005

Cod. **MAGN1076 cat.6** Nero / Black RAL9005



PANNELLO PASSAGGIO CAVI 19" (1U) CON SPAZZOLE 19" CABLE PANEL (1HE) WITH BRUSH



Cod. **MAGN0708** Grigio / Grey RAL7035

Cod. **MAGN0709** Nero / Black RAL9005

PANNELLI CIECHI 19" 19" BLIND PANELS



Cod. **MAGN0288** 1 U / HE Grigio / Grey RAL7035

Cod. **95295320** 1,5 U / HE Grigio / Grey RAL7035

Cod. **MAGN0396** 2 U / HE Grigio / Grey RAL7035

Cod. **95295330** 3 U / HE Grigio / Grey RAL7035

Cod. **MAGN0109** 1 U / HE Nero / Black RAL9005

Cod. **MAGN0025** 1,5 U / HE Nero / Black RAL9005

Cod. **MAGN0110** 2 U / HE Nero / Black RAL9005

Cod. **MAGN0026** 3 U / HE Nero / Black RAL9005

**KIT DI VITI, DADI IN GABBIA E RONDELLE
IN NYLON M6 (30+30+30)
SET OF SCREWS, NYLON WASHERS
AND CAGES NUTS M6 (30+30+30)**

Cod. **MAGN0142**



**COPPIA DI MONTANTI 19" POSTERIORI
PER ARMADIETTI PK
19" REAR FRAME FOR PK
ENCLOSURES**

Cod. **MAGN0920** 6 U / HE Cod. **MAGN0922** 12 U / HE

Cod. **MAGN0921** 9 U / HE Cod. **MAGN0923** 15 U / HE
Cod. **MAGN0992** 21 U / HE



**GUIDAFILO VERTICALE
VERTICAL CABLE HOLDER**

Anello da fissare sui montanti 19"
lateralmente ai pannelli.

*Cable hanger to be fitted on 19"
uprights to the side of the panels.*

Cod. **306040** 1,5 U / HE



**LAMPADA NEON CON INTERRUTTORE
NEON TUBE WITH SWITCH**



Ogni confezione comprende anche 2 squadrette di fissaggio.
Each pack includes 2 brackets for fixing.

Cod. **95295616** 18W Lunghezza / Length 650 mm

Cod. **95295615** 36W Lunghezza / Length 1250 mm

**PANNELLO 19" (1U) CON LAMPADA
19" PANEL (1HE) WITH LAMP**

Cod. **MAGN0928**

Grigio / Grey RAL7035

Cod. **MAGN0929**

Nero / Black RAL9005



Questa lampada è predisposta per il montaggio sui montanti 19" e
permette di illuminare il fronte cablato dell'armadio.
8W - 220 V

*This lamp may be fitted to the 19" uprights and lights up the cabled
area of the rack.*
8 W - 220 V

**ZOCCOLO PER INSTALLAZIONE A
PAVIMENTO
PEDESTAL FOR FLOOR INSTALLATION**

Ancoraggio con biadesivo.

Cod. **95298522**

